



**APEX DYNAMICS, INC.**

# **AL / ALR Series**

*High Precision Planetary  
Gearboxes With Adapting  
Timing Belt Pulley*



**Stainless**



Planet gears turn on **solid uncaged needle roller bearings** for increased stiffness and the maximum number of contact points. Hardened thrust washers allow the close control of clearances in order to further reduce backlash.

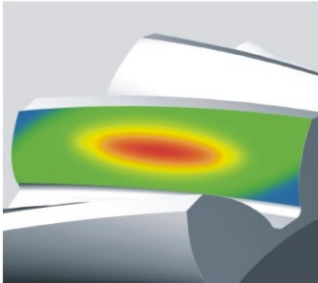

Industry-leading gear performance is attained with our **HeliTopo technology**. **Ease off of the tooth profile and lead crowning** optimizes the gear mesh under load and achieves maximum tooth surface contact.

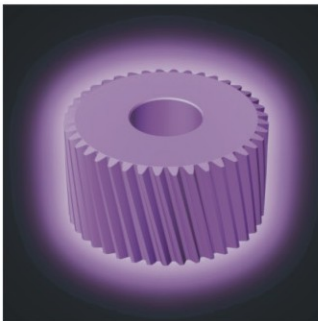

**Our in-house plasma nitriding heat treatment** process allows the hardness of the gear flanks to reach over 900Hv for superior wear resistance and still maintain a core hardness of 30HRC for toughness and resistance to shock loading.

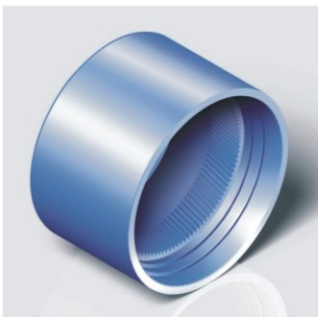

**The helical internal ring gear** is machined directly into the pulley itself for perfect concentricity and maximized internal diameter. The possibility to optimize the tooth number and module allows the torque capacity to be increased considerably.



**Helical gear design.** Helical gearing increases the tooth to tooth contact ratio by as much as 33%, providing benefits of improved smoothness, decreased noise and backlash, and increased torque capacity. The helix angle is carefully chosen to gain these advantages while not producing excessive axial forces.

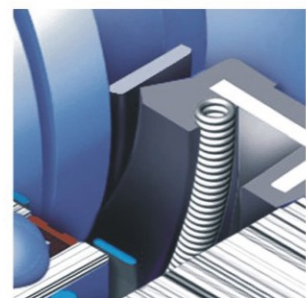
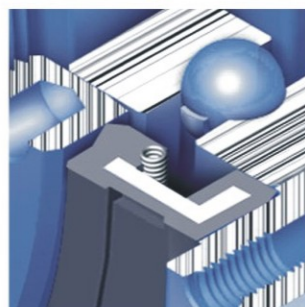
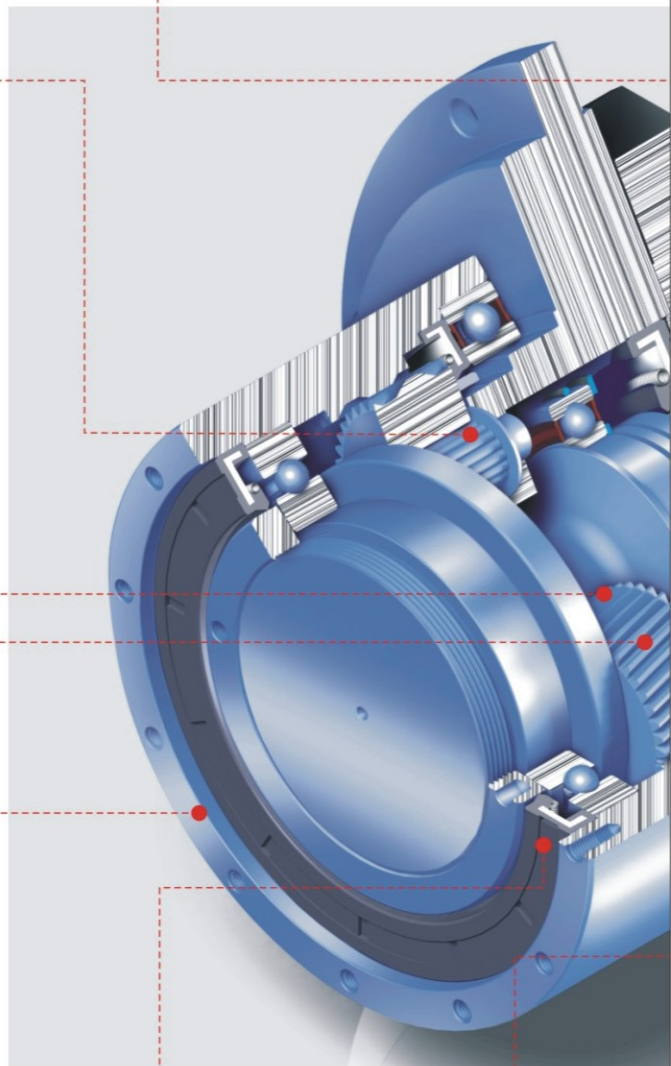



# AL / ALR Series

## Characteristic Highlights

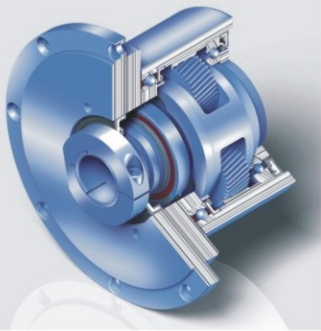

**Patented planet carrier design** mounts the sun gear bearing directly into the planet carrier in order to eliminate misalignment. This exclusive design offers great advantages in decreased noise, vibration and transmission errors and losses. Precision ball bearings are oversized and optimally positioned to maximize the load capacity and service life of the unit.

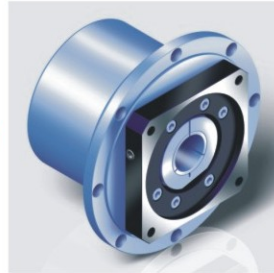

**Extremely compact design** allows the use of short motor adapter allowing fitment in the most challenging locations. Simple modular design readily adapts to any motor in minutes.

**Lubrication by synthetic Nyogel 792D grease** for smooth operation over the whole service life, regardless of mounting orientation. Sealed to **IP65** standard for protection and maintenance-free performance.

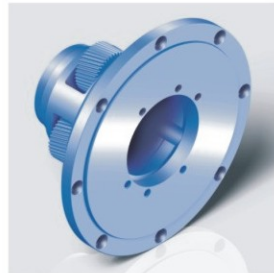
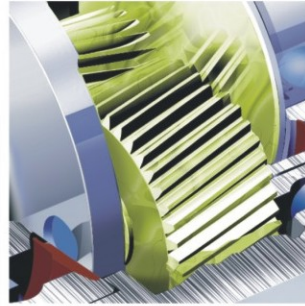

**One-piece carrier and mounting flange** assures concentricity and alignment of all the rotating parts and the strength and rigidity of the whole system. Supporting two oversized bearings, the whole structure can withstand high radial loads through torque and belt tension.

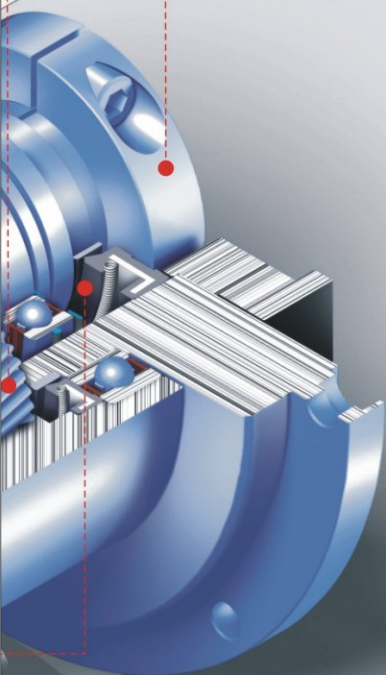

## ALR Series

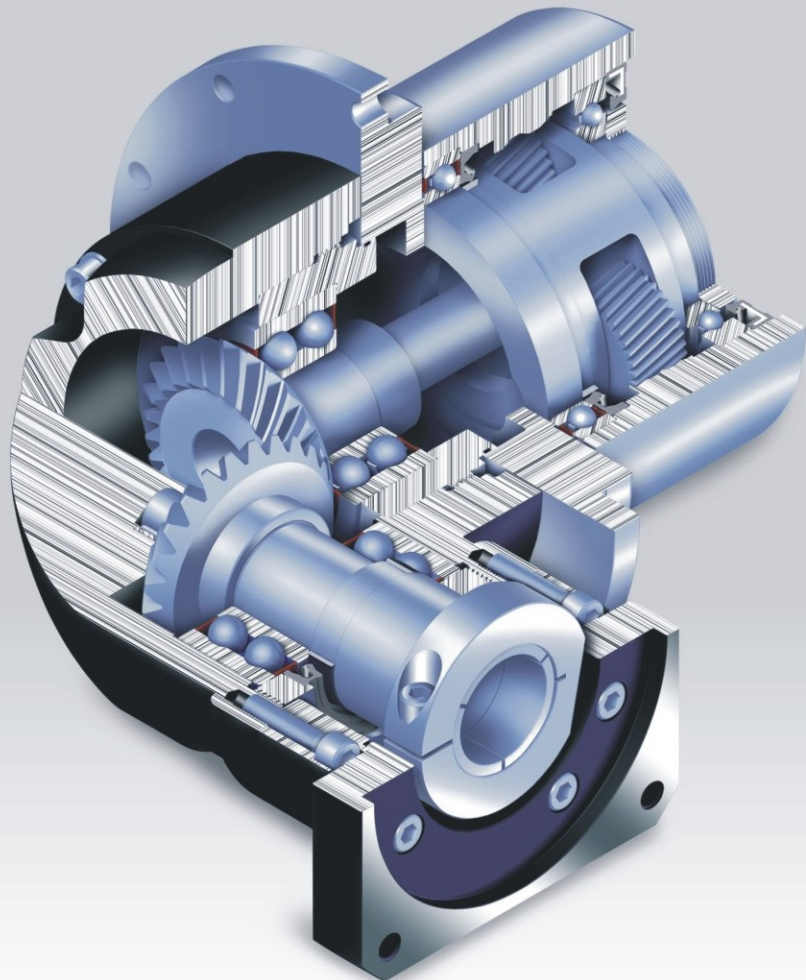

**ALR version** with 90° input via spiral bevel gear. Featuring an extremely short, rigid housing with full compatibility to any motor.

**Patented sealing system** featuring a TiCN coated shaft surface that eliminates leakage and increases service life to over 30,000 hours. The high tech coating, with a surface quality of 0.2  $\mu\text{m}$  and hardness of 3700 Hv. Interfaces with our proprietary seal, decreasing wear and running temperature.



# AL Series

## Specifications

### Gearbox Performance

Model No.	Stage	Ratio <sup>1</sup>	AL070	AL095	AL110	AL150	AL190	AL230	AL280	
Nominal Output Torque $T_{2N}$	Nm	1	2	9	36	90	195	342	588	1,140
			3	12	48	120	260	520	1,040	1,680
			4	15	60	150	325	650	1,200	2,000
			5	18	55	150	310	600	1,100	1,900
			6	19	50	140	300	550	1,100	1,800
			7	17	45	120	260	500	1,000	1,600
			8	14	40	100	230	450	900	1,500
			9	14	40	100	230	450	900	1,500
			Nm	2	10	9	36	90	195	342
	15	12			48	120	260	520	1,040	1,680
	20	15			60	150	325	650	1,200	2,000
	25	18			55	150	310	600	1,100	1,900
	30	19			50	140	300	550	1,100	1,800
	35	17			45	120	260	500	1,000	1,600
	40	22			60	100	230	650	1,200	2,000
	45	14			40	100	230	450	900	1,500
	50	18			55	150	310	600	1,100	1,900
	Max. Output Torque $T_{2B}$	Nm	1,2	2~90	3 times of Nominal Output Torque					
Nominal Input Speed $n_{1n}$	rpm	1	2	3,000	3,000	2,600	2,600	2,000	2,000	1,350
		1,2	3~90	5,000	5,000	4,000	4,000	3,000	3,000	2,000
Max. Input Speed $n_{1B}$	rpm	1	2	6,000	6,000	5,200	5,200	4,000	4,000	2,700
		1,2	3~90	10,000	10,000	8,000	8,000	6,000	6,000	4,000
Continuous Input Speed $s_1$	rpm	1	2	2,500	2,500	2,000	2,000	1,800	1,800	1,200
		1,2	3~90	4,000	4,000	3,000	3,000	2,500	2,500	1,600
Micro Backlash $P_0$	arcmin	1	2~9	-	-	≤1	≤1	≤1	≤1	≤1
		2	10~90	-	-	-	≤3	≤3	≤3	≤3
Reduced Backlash $P_1$	arcmin	1	2~9	≤3	≤3	≤3	≤3	≤3	≤3	≤3
		2	10~90	≤5	≤5	≤5	≤5	≤5	≤5	≤5
Standard Backlash $P_2$	arcmin	1	2~9	≤5	≤5	≤5	≤5	≤5	≤5	≤5
		2	10~90	≤7	≤7	≤7	≤7	≤7	≤7	≤7
Torsional Stiffness	Nm/arcmin	1,2	2~90	7	13	31	82	151	440	1,006
Max. Radial Load $F_{2r}^2$	N	1,2	2~90	2,120	4,450	6,500	10,950	15,700	25,000	34,200
Max. Axial Load $F_{2aB}^2$	N	1,2	2~90	1,060	2,225	3,200	5,475	7,850	12,500	17,100
Service Life	hr	1,2	2~90	30,000*						
Efficiency $\eta$	%	1	2~9	≥97%						
		2	10~90	≥94%						
Weight	kg	1	2~9	0.9	2.3	4.1	9	17.5	36.3	57.1
		2	10~90	1.2	2.4	4.3	10	20	36.9	63.3
Operating Temp	°C	1,2	2~90	-10°C~+90°C						
Lubrication		1,2	2~90	synthetic gear grease (NYOGEL 792D)						
Degree of Gearbox Protection		1,2	2~90	IP65						
Mounting Position		1,2	2~90	all directions						
Noise Level ( $n_1=3000$ rpm)	dB	1,2	2~90	≤56	≤58	≤60	≤63	≤65	≤67	≤70

1. Ratio ( $i=N_{in}/N_{out}$ )  
\*S1 service life 15,000 hrs

2. Applied to the center of output housing @ 100 rpm

# Dimensions (1-stage, Ratio i=2~9)

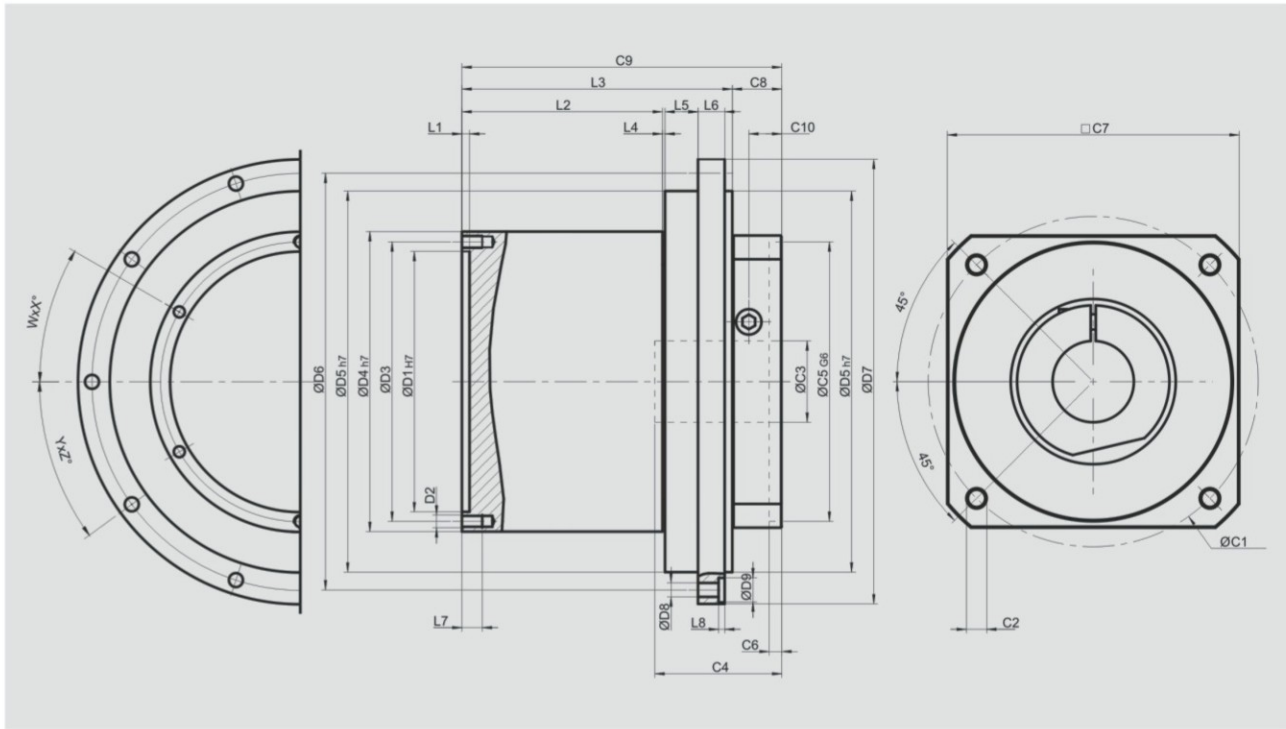

[unit: mm]

Dimension	AL070	AL095	AL110	AL150	AL190	AL230	AL280
D1 <sub>h7</sub>	37.5	55.5	70.5	102.5	132.5	168.5	204.5
D2	M3 x 0.5P	M3 x 0.5P	M4 x 0.7P	M5 x 0.8P	M5 x 0.8P	M6 x 1P	M6 x 1P
D3	42	61.5	78.5	110	142.5	179	216
D4 <sub>h7</sub>	47.7	67.3	87.3	118.1	152.8	190	229.2
D5 <sub>h7</sub>	70	95	110	150	190	230	280
D6	80	108	124	164	208	246	296
D7	90	120	135	175	225	262	312
D8	4.5	5.5	5.5	5.5	9	9	9
D9	8	9.5	--	9.5	14	--	--
L1	3	3	3	3	4	3	3
L2	36	55.5	60.5	79	94	115	116
L3	50.5	72	84	106.5	124.5	162	169
L4	0.5	0.5	0.5	1	1	1.5	1.5
L5	6	7	10	13	15	18	22
L6	6	7	7.5	10.5	12	15	18
L7	6	6	8	9	9	11	11
L8	2.4	3.4	--	2.4	6.1	--	--
C1 <sup>3</sup>	46	70	100	130	165	215	235
C2 <sup>3</sup>	M4 x 0.7P	M5 x 0.8P	M6 x 1P	M8 x 1.25P	M10 x 1.5P	M12 x 1.75P	M12 x 1.75P
C3 <sup>3</sup>	≤11	* ≤14 / ≤16	≤19 / ≤24	≤32	≤38	≤48	≤55
C4 <sup>3</sup>	30	34	40	50	60	85	116
C5 <sup>3 G6</sup>	30	50	80	110	130	180	200
C6 <sup>3</sup>	3.5	8	4	5	6	6	6
C7 <sup>3</sup>	48	60	90	115	142	190	220
C8 <sup>3</sup>	19.5	19	17	19.5	22.5	29	63
C9 <sup>3</sup>	70	91	101	126	147	191	232
C10 <sup>3</sup>	13.25	13.5	10.75	13	15	20.75	53.5
W	6	8	8	8	12	12	12
X	60	45	45	45	30	30	30
Y	6	10	10	10	10	10	12
Z	60	36	36	36	36	36	30

3. C1~C10 are motor specific dimensions (metric std shown). Refer to [apexdyna.com](http://apexdyna.com) and design tool to view your specific motor mounting system.  
 \*AL095 ratio 4, 9 offers C3 ≤ 16 option.



# AL Series

## Dimensions (2-stage, Ratio $i=10\sim90$ )

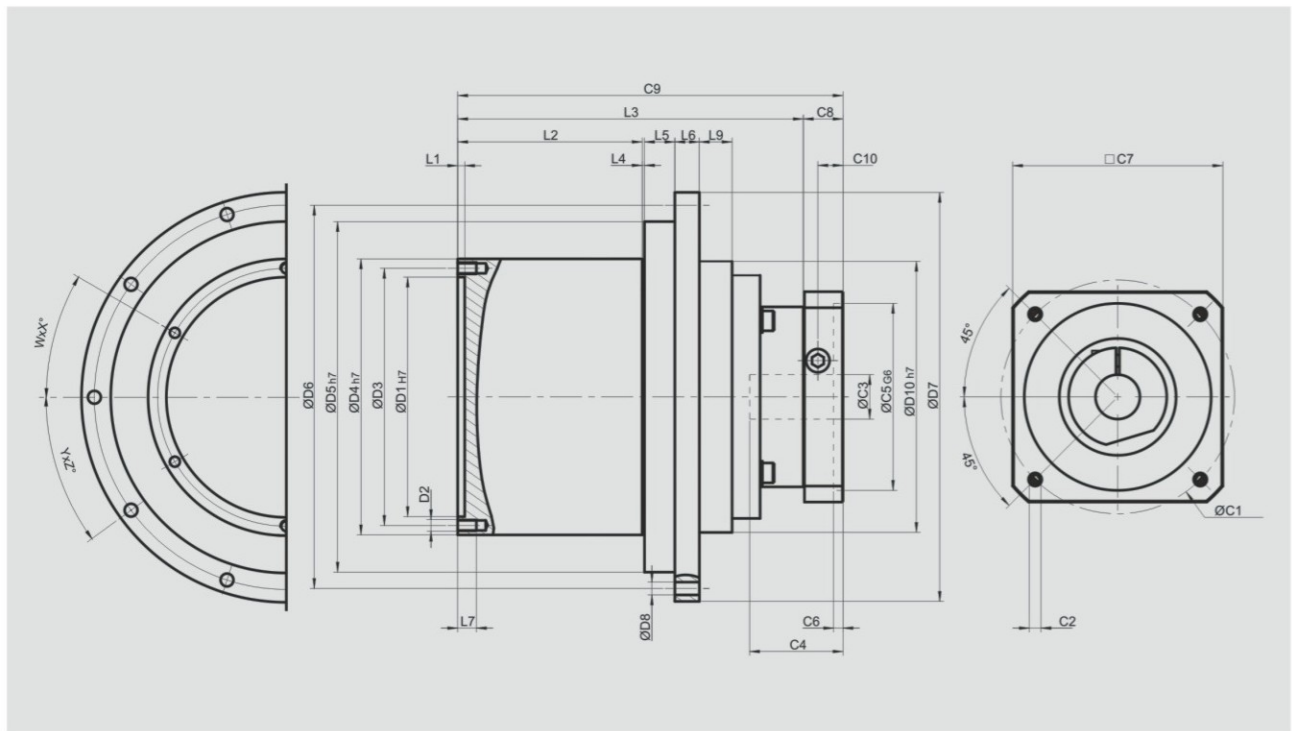

[unit: mm]

Dimension	AL070	AL095	AL110	AL150	AL190	AL230	AL280
D1 <sub>H7</sub>	37.5	55.5	70.5	102.5	132.5	168.5	204.5
D2	M3 x 0.5P	M3 x 0.5P	M4 x 0.7P	M5 x 0.8P	M5 x 0.8P	M6 x 1P	M6 x 1P
D3	42	61.5	78.5	110	142.5	179	216
D4 <sub>H7</sub>	47.7	67.3	87.3	118.1	152.8	190	229.2
D5 <sub>H7</sub>	70	95	110	150	190	230	280
D6	80	108	124	164	208	246	296
D7	90	120	135	175	225	262	312
D8	4.5	5.5	5.5	5.5	9	9	9
D10 <sub>H7</sub>	70	62	82	116	145	178	224
L1	3	3	3	3	4	3	3
L2	36	55.5	60.5	79	94	115	116
L3	78.5	97.5	116.5	148	181	219.5	253.5
L4	0.5	0.5	0.5	1	1	1.5	1.5
L5	6	7	10	13	15	18	22
L6	6	7	7.5	10.5	12	15	18
L7	6	6	8	9	9	11	11
L9	2	8	12	14	18	22	26.5
C1 <sup>4</sup>	46	46	70	100	130	165	215
C2 <sup>4</sup>	M4 x 0.7P	M4 x 0.7P	M5 x 0.8P	M6 x 1P	M8 x 1.25P	M10 x 1.5P	M12 x 1.75P
C3 <sup>4</sup>	≤11	* ≤11 / ≤12	* ≤14 / ≤15.875 / ≤16	≤19 / ≤24	≤32	≤38	≤48
C4 <sup>4</sup>	30	30	34	40	50	60	85
C5 <sup>4</sup> G6	30	30	50	80	110	130	180
C6 <sup>4</sup>	3.5	3.5	8	4	5	6	6
C7 <sup>4</sup>	48	48	60	90	115	142	190
C8 <sup>4</sup>	19.5	19.5	19	17	19.5	22.5	29
C9 <sup>4</sup>	98	117	135.5	165	200.5	242	282.5
C10 <sup>4</sup>	13.25	13.25	13.5	10.75	13	15	20.75
W	6	8	8	8	12	12	12
X	60	45	45	45	30	30	30
Y	6	10	10	10	10	10	12
Z	60	36	36	36	36	36	30

4. C1-C10 are motor specific dimensions (metric std shown). Refer to apexdyna.com and design tool to view your specific motor mounting system.  
 \*AL095 ratio 10-45 offers C3 ≤ 12 option. \*AL110 ratio 10-45 offers C3 ≤ 15.875 / ≤ 16 option.

# ALR Series

## Specifications

### Gearbox Performance

Model No.	Stage	Ratio <sup>1</sup>	ALR070	ALR095	ALR110	ALR150	ALR190	ALR230	ALR280		
Nominal Output Torque $T_{2N}$	1	2	9	36	90	195	342	588	1,140		
		3	12	48	120	260	520	1,040	1,680		
		4	15	60	150	325	650	1,200	2,000		
		5	18	55	150	310	600	1,100	1,900		
		6	19	50	140	300	550	1,100	1,800		
		7	17	45	120	260	500	1,000	1,600		
		8	14	40	100	230	450	900	1,500		
		9	14	40	100	230	450	900	1,500		
		10	-	55	150	310	600	1,100	1,900		
		2	10	9	-	-	-	-	-	-	-
	15		12	48	120	260	520	1,040	1,680		
	20		15	60	150	325	650	1,200	2,000		
	25		18	55	150	310	600	1,100	1,900		
	30		19	50	140	300	550	1,100	1,800		
	35		17	45	120	260	500	1,000	1,600		
	40		22	60	100	230	650	1,200	2,000		
	45		14	40	100	230	450	900	1,500		
	50		18	55	150	310	600	1,100	1,900		
	60		19	50	140	300	550	1,100	1,800		
	70		17	45	120	260	500	1,000	1,600		
	80		14	40	100	230	450	900	1,500		
	90		14	40	100	230	450	900	1,500		
	100		-	-	150	310	600	1,100	1,900		
	120		-	-	140	300	550	1,100	1,800		
	140		-	-	120	260	500	1,000	1,600		
	160		-	-	100	230	450	900	1,500		
	180		-	-	100	230	450	900	1,500		
	Max. Output Torque $T_{2B}$	Nm	1,2	2~180	3 times of Nominal Output Torque						
	Nominal Input Speed $n_{1N}$	rpm	1	2	3,000	3,000	2,600	2,600	2,000	2,000	1,350
			1,2	3~180	5,000	5,000	4,000	4,000	3,000	3,000	2,000
Max. Input Speed $n_{1B}$	rpm	1	2	6,000	6,000	5,200	5,200	4,000	4,000	2,700	
		1,2	3~180	10,000	10,000	8,000	8,000	6,000	6,000	4,000	
Continuous Input Speed $s_1$	rpm	1	2	2,500	2,500	2,000	2,000	1,800	1,800	1,200	
		1,2	3~180	4,000	4,000	3,000	3,000	2,500	2,500	1,600	
Micro Backlash $P_0$	arcmin	1	2~10	-	-	≤2	≤2	≤2	≤2	≤2	
		2	15~180	-	-	≤4	≤4	≤4	≤4	≤4	
Reduced Backlash $P_1$	arcmin	1	2~10	≤4	≤4	≤4	≤4	≤4	≤4	≤4	
		2	15~180	≤7	≤7	≤7	≤7	≤7	≤7	≤7	
Standard Backlash $P_2$	arcmin	1	2~10	≤6	≤6	≤6	≤6	≤6	≤6	≤6	
		2	15~180	≤9	≤9	≤9	≤9	≤9	≤9	≤9	
Torsional Stiffness	Nm/arcmin	1,2	2~180	7	13	31	82	151	440	1,006	
Max. Radial Load $F_{2RB}^2$	N	1,2	2~180	2,120	4,450	6,500	10,950	15,700	25,000	34,200	
Max. Axial Load $F_{2aB}^2$	N	1,2	2~180	1,060	2,225	3,250	5,475	7,850	12,500	17,100	
Service Life	hr	1,2	2~180	30,000*							
Efficiency $\eta$	%	1	2~10	≥95%							
		2	15~180	≥92%							
Weight	kg	1	2~10	1.4	3.1	6.8	13.8	27.3	53.2	83.3	
		2	15~180	1.5	2.8	5	12.5	24.3	45.4	78.8	
Operating Temp	°C	1,2	2~180	-10°C~+90°C							
Lubrication		1,2	2~180	synthetic gear grease (NYOGEL 792D)							
Degree of Gearbox Protection		1,2	2~180	IP65							
Mounting Position		1,2	2~180	all directions							
Noise Level ( $n_1=3000$ rpm)	dB	1,2	2~180	≤61	≤63	≤65	≤68	≤70	≤72	≤74	

1. Ratio ( $i=N_{in}/N_{out}$ )

\* S1 service life 15,000 hrs

2. Applied to the center of output housing @ 100 rpm



# ALR Series

## Dimensions (1-stage, Ratio $i=2\sim 10$ )

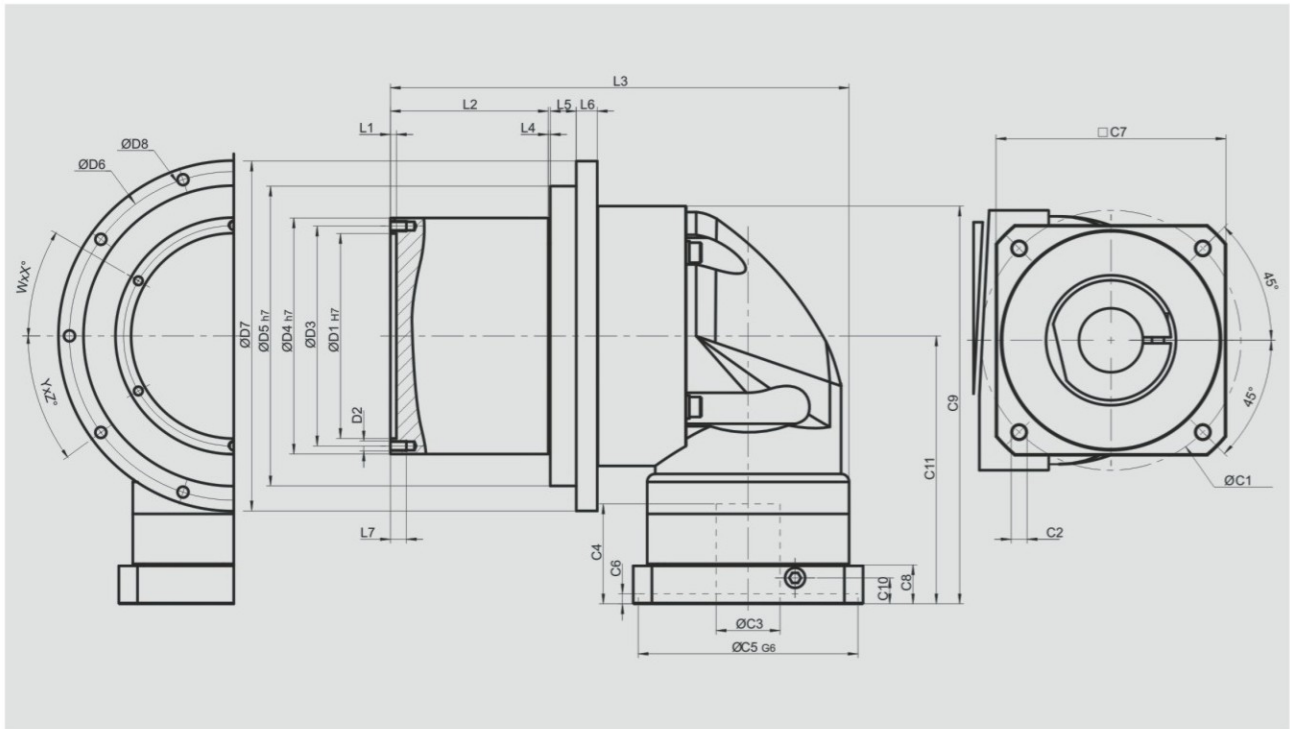

[unit: mm]

Dimension	ALR070	ALR095	ALR110	ALR150	ALR190	ALR230	ALR280
D1 <sub>H7</sub>	37.5	55.5	70.5	102.5	132.5	168.5	204.5
D2	M3 x 0.5P	M3 x 0.5P	M4 x 0.7P	M5 x 0.8P	M5 x 0.8P	M6 x 1P	M6 x 1P
D3	42	61.5	78.5	110	142.5	179	216
D4 <sub>h7</sub>	47.7	67.3	87.3	118.1	152.8	190	229.2
D5 <sub>h7</sub>	70	95	110	150	190	230	280
D6	80	108	124	164	208	246	296
D7	90	120	135	175	225	262	312
D8	4.5	5.5	5.5	5.5	9	9	9
L1	3	3	3	3	4	3	3
L2	36	55.5	60.5	79	94	115	116
L3	106.5	144	183.5	229.5	278	339.5	382.5
L4	0.5	0.5	0.5	1	1	1.5	1.5
L5	6	7	10	13	15	18	22
L6	6	7	7.5	10.5	12	15	18
L7	6	6	8	9	9	11	11
C1 <sup>3</sup>	46	70	100	130	165	215	235
C2 <sup>3</sup>	M4 x 0.7P	M5 x 0.8P	M6 x 1P	M8 x 1.25P	M10 x 1.5P	M12 x 1.75P	M12 x 1.75P
C3 <sup>3</sup>	≤11	≤14 / ≤16	≤19 / ≤24	≤32	≤38	≤48	≤55
C4 <sup>3</sup>	30	34	40	50	60	85	116
C5 <sup>3</sup> G6	30	50	80	110	130	180	200
C6 <sup>3</sup>	3.5	8	4	5	6	6	6
C7 <sup>3</sup>	48	60	90	115	142	190	220
C8 <sup>3</sup>	19.5	19	17	19.5	22.5	29	63
C9 <sup>3</sup>	100.5	116.5	159.5	199	245.5	316	398.5
C10 <sup>3</sup>	13.25	13.5	10.75	13	15	20.75	53.5
C11 <sup>3</sup>	74	81.5	107.5	134	164.5	213.5	268.5
W	6	8	8	8	12	12	12
X	60	45	45	45	30	30	30
Y	6	10	10	10	10	10	12
Z	60	36	36	36	36	36	30

3. C1-C11 are motor specific dimensions (metric std shown). Refer to apexdyna.com and design tool to view your specific motor mounting system.



# Dimensions (2-stage, Ratio $i=15\sim 180$ )

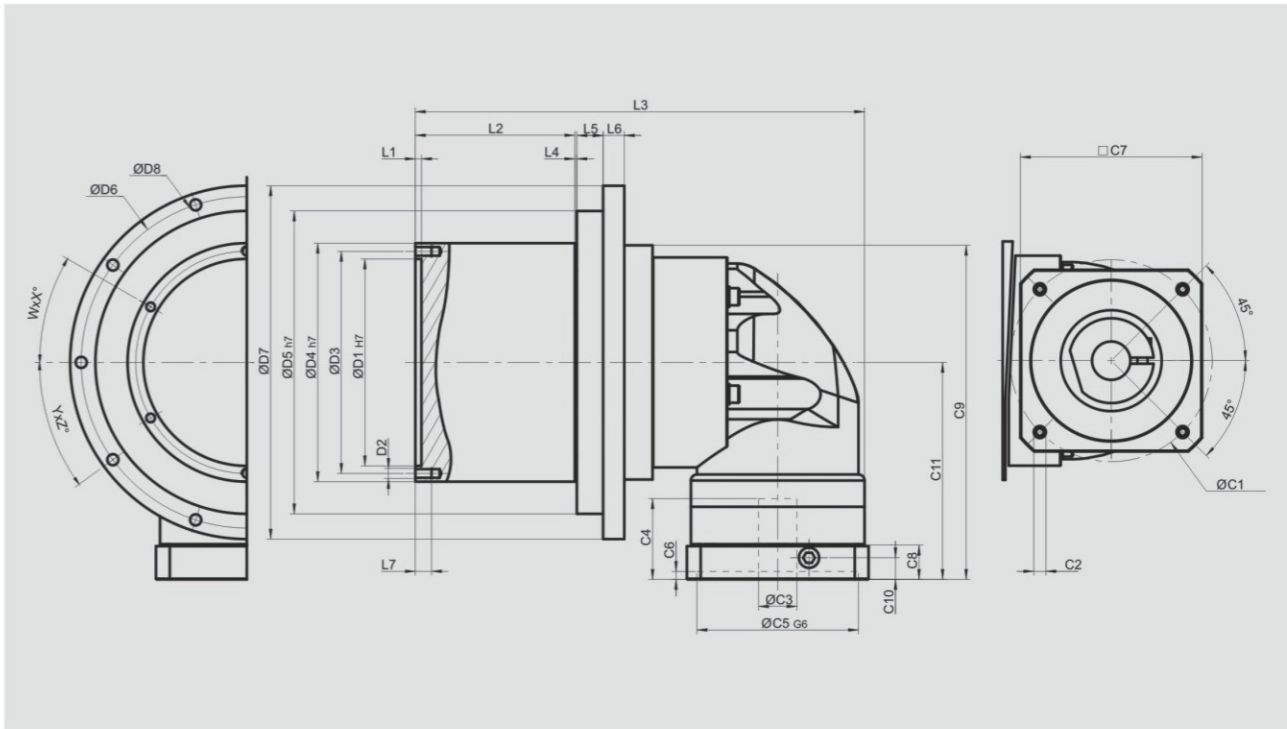

[unit: mm]

Dimension	ALR070	ALR095	ALR110	ALR150	ALR190	ALR230	ALR280
D1 <sub>H7</sub>	37.5	55.5	70.5	102.5	132.5	168.5	204.5
D2	M3 x 0.5P	M3 x 0.5P	M4 x 0.7P	M5 x 0.8P	M5 x 0.8P	M6 x 1P	M6 x 1P
D3	42	61.5	78.5	110	142.5	179	216
D4 <sub>H7</sub>	47.7	67.3	87.3	118.1	152.8	190	229.2
D5 <sub>H7</sub>	70	95	110	150	190	230	280
D6	80	108	124	164	208	246	296
D7	90	120	135	175	225	262	312
D8	4.5	5.5	5.5	5.5	9	9	9
L1	3	3	3	3	4	3	3
L2	36	55.5	60.5	79	94	115	116
L3	122.5	141.5	164.5	222.5	266	327.5	374
L4	0.5	0.5	0.5	1	1	1.5	1.5
L5	6	7	10	13	15	18	22
L6	6	7	7.5	10.5	12	15	18
L7	6	6	8	9	9	11	11
C1 <sup>4</sup>	46	46	70	100	130	165	215
C2 <sup>4</sup>	M4 x 0.7P	M4 x 0.7P	M5 x 0.8P	M6 x 1P	M8 x 1.25P	M10 x 1.5P	M12 x 1.75P
C3 <sup>4</sup>	≤11	≤11 / ≤12	≤14 / ≤15.875 / ≤16	≤19 / ≤24	≤32	≤38	≤48
C4 <sup>4</sup>	30	30	34	40	50	60	85
C5 <sup>4</sup> <sub>G6</sub>	30	30	50	80	110	130	180
C6 <sup>4</sup>	3.5	3.5	8	4	5	6	6
C7 <sup>4</sup>	48	48	60	90	115	142	190
C8 <sup>4</sup>	19.5	19.5	19	17	19.5	22.5	29
C9 <sup>4</sup>	100.5	105	122.5	165.5	206.5	253.5	325.5
C10 <sup>4</sup>	13.25	13.25	13.5	10.75	13	15	20.75
C11 <sup>4</sup>	74	74	81.5	107.5	134	164.5	213.5
W	6	8	8	8	12	12	12
X	60	45	45	45	30	30	30
Y	6	10	10	10	10	10	12
Z	60	36	36	36	36	36	30

4. C1-C11 are motor specific dimensions (metric std shown). Refer to Apexdyna.com and Design Tool to view your specific motor mounting system.

# Belt Pulley Designs

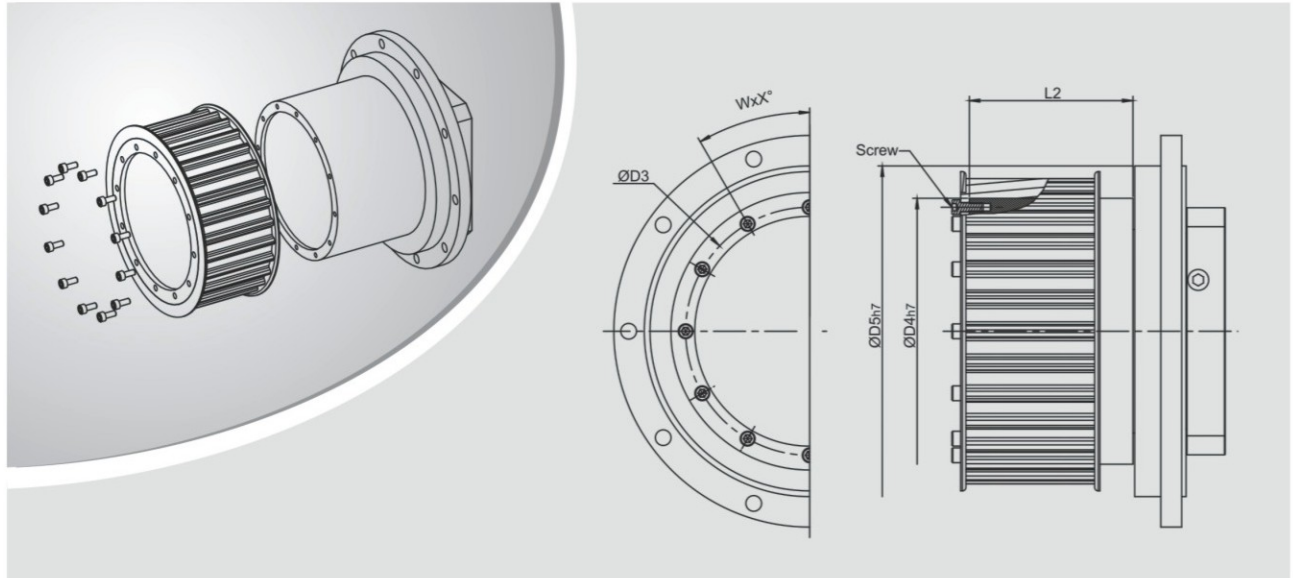

[unit: mm]

## Key Dimension For Pulley Design

Dimension	AL070	AL095	AL110	AL150	AL190	AL230	AL280
	ALR070	ALR095	ALR110	ALR150	ALR190	ALR230	ALR280
L2	36	55.5	60.5	79	94	115	116
D3	42	61.5	78.5	110	142.5	179	216
D4 <sub>h7</sub>	47.7	67.3	87.3	118.1	152.8	190	229.2
D5 <sub>h7</sub>	70	95	110	150	190	230	280
Screw	M3 x 0.5P	M3 x 0.5P	M4 x 0.7P	M5 x 0.8P	M5 x 0.8P	M6 x 1P	M6 x 1P
W	6	8	8	8	12	12	12
X	60	45	45	45	30	30	30

## AL Gearbox Inertia

Model No.	Stage	Ratio	AL070	AL095	AL110	AL150	AL190	AL230	AL280
Mass Moments of Inertia J,	1	2	0.03	0.16	0.61	3.25	9.21	28.98	69.91
		3	0.03	0.14	0.48	2.74	7.54	23.67	54.37
		4	0.03	0.13	0.47	2.71	7.42	23.29	53.27
		5	0.03	0.13	0.45	2.65	7.25	22.75	51.27
		6	0.03	0.13	0.45	2.62	7.14	22.48	50.97
		7	0.03	0.13	0.44	2.58	7.07	22.59	50.84
		8	0.03	0.13	0.44	2.57	7.04	22.53	50.63
		9	0.03	0.13	0.44	2.57	7.03	22.51	50.56
		2	10	0.03	0.03	0.13	0.47	2.71	7.42
	15		0.03	0.03	0.13	0.47	2.71	7.42	23.29
	20		0.03	0.03	0.13	0.47	2.71	7.42	23.29
	25		0.03	0.03	0.13	0.47	2.71	7.42	23.29
	30		0.03	0.03	0.13	0.47	2.71	7.42	23.29
	35		0.03	0.03	0.13	0.47	2.71	7.42	23.29
	40		0.03	0.03	0.13	0.47	2.71	7.42	23.29
	45		0.03	0.03	0.13	0.47	2.71	7.42	23.29
	50		0.03	0.03	0.13	0.44	2.57	7.03	22.51
	60	0.03	0.03	0.13	0.44	2.57	7.03	22.51	
70	0.03	0.03	0.13	0.44	2.57	7.03	22.51		
80	0.03	0.03	0.13	0.44	2.57	7.03	22.51		
90	0.03	0.03	0.13	0.44	2.57	7.03	22.51		

## ALR Gearbox Inertia

Model No.	Stage	Ratio	ALR070	ALR095	ALR110	ALR150	ALR190	ALR230	ALR280
Mass Moments of Inertia J,	1	2~9	0.09	0.35	2.25	6.84	23.4	68.9	135.4
		10	-	0.07	1.87	6.25	21.8	65.6	119.8
	2	10	0.09	-	-	-	-	-	-
		15~90	0.09	0.09	0.35	2.25	6.84	23.4	68.9
		90~180	-	-	0.31	1.87	6.25	21.8	65.6



# Ordering Code

## AL Series

**AL070**

–

**010**

–

**P1**

/

**MOTOR**

### Gearbox Size:

AL070, AL095, AL110, AL150,  
AL190, AL230, AL280

### Backlash:

P0: Micro Backlash  
P1: Reduced Backlash  
P2: Standard Backlash

### Ratio:

1 Stage: 2, 3, 4, 5, 6, 7, 8, 9  
2 Stage: 10, 15, 20, 25, 30, 35, 40, 45, 50, 60, 70, 80, 90

### Motor Designation:

Manufacturer Type  
And Model

**Ordering Example: AL070-010-P1 / SIEMENS 1FT6 041-4AF71**

## ALR Series

**ALR070**

–

**010**

–

**P1**

/

**MOTOR**

### Gearbox Size:

ALR070, ALR095, ALR110, ALR150,  
ALR190, ALR230, ALR280

### Backlash:

P0: Micro Backlash  
P1: Reduced Backlash  
P2: Standard Backlash

### Ratio:

1 Stage: 2, 3, 4, 5, 6, 7, 8, 9, 10  
2 Stage: 15, 20, 25, 30, 35, 40, 45, 50, 60, 70, 80, 90,  
100, 120, 140, 160, 180

### Motor Designation:

Manufacturer Type  
And Model

**Ordering Example: ALR070-010-P1 / SIEMENS 1FT5 034-OAK71**

■ Please visit our website for newest update data.

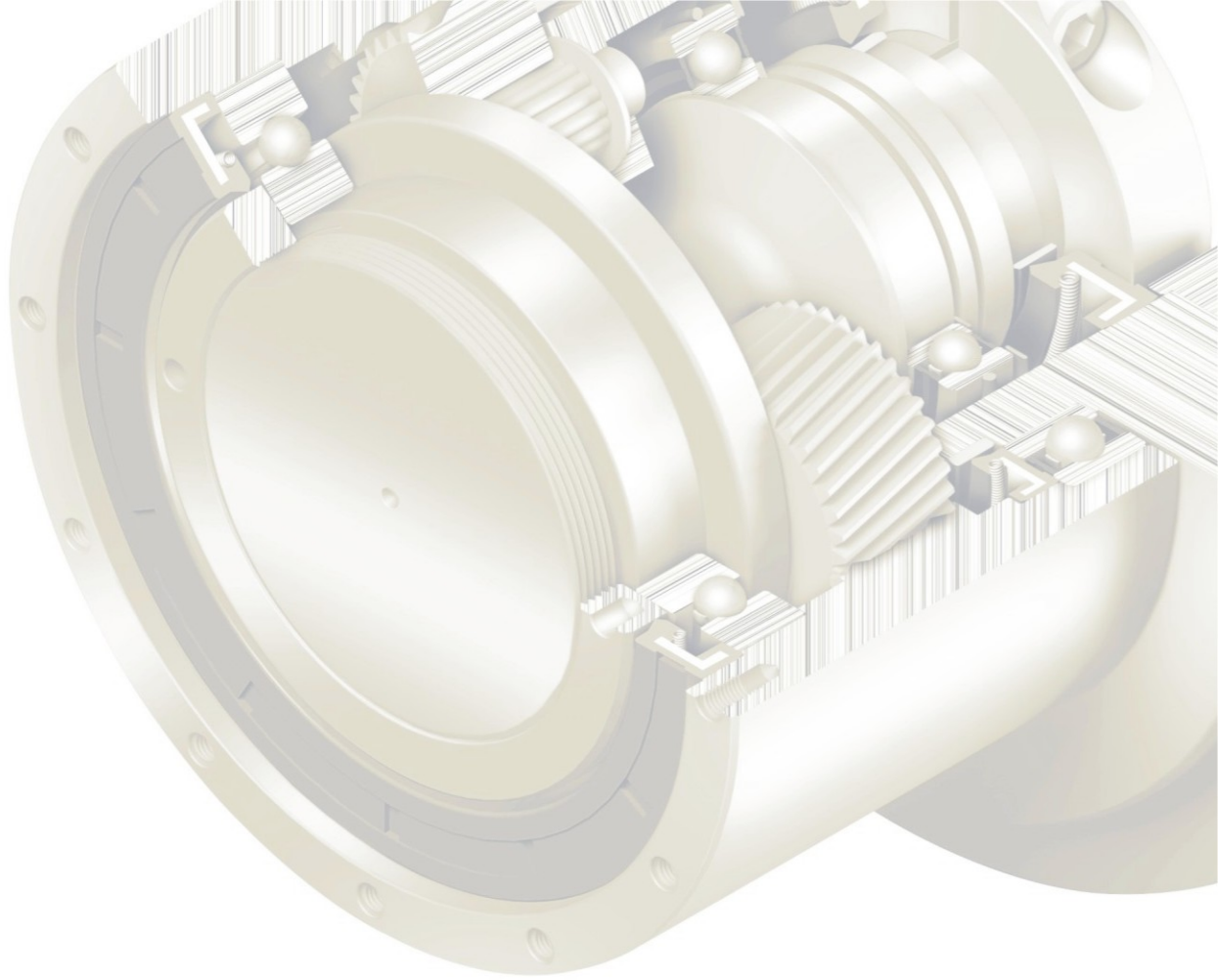

# **AL / ALR** Series

[www.apexdyna.com](http://www.apexdyna.com)



**APEX DYNAMICS, INC.**

No. 6, 20th Rd., Taichung Industrial Park, Taichung, Taiwan, R.O.C.

Tel: 886 4 23550219 / Fax: 886 4 23550218

E-mail: [sales@apexdyna.com](mailto:sales@apexdyna.com)

Website: [www.apexdyna.com](http://www.apexdyna.com)